

**Direct Video Synthesizer (Analog), 1970**  
**Beck Video Weaver (Digital), 1974**  
**STEPHEN BECK**

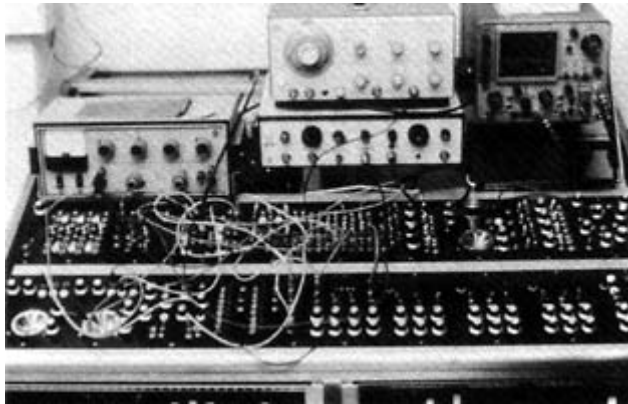

Direct Video Synthesizer



The Beck Video Weaver, and the maniac himself, Stephen Beck.

IN THE SUMMER OF 1971 we went to San Francisco on an invitation from Paul Kaufman. The days were cold and we often drove over the bay to Mount Diablo to warm our bones. The National Center for Experiments in Television was in a state of disintegration and there were bitter feelings about things we did not understand.

There were two instruments we were eager to explore: "The Bench" and Beck's DVS. The Bench appeared to us a monstrous labyrinth, months away from a conquest. It had many knobs and joysticks, many ways to alter or combine images. For us it qualified as a synthetic provider, something to be avoided. We were in our analytic phase and Beck's device appeared much more tempting, much more mysterious. The label itself had a nicely provocative slant: Direct Video Synthesizer.

Although not long lasting, there was a period in video when the subject of representation was discussed, resembling the dialog between musique concrete and the Synthesizer or the Bazanian discourse of filmic reality. The appropriation of images was the topic, those taken from God/Nature through the camera versus those constructed inside the instrument. There was a clear interest in machine-made forms as far away from nature as possible. The synthetic principle was the talk of the day.

Beck also presented a rather scholastic theory of synthetic pictorialism, something he later meticulously explained in his didactic tape. Although we got inspired by Beck in general, we

never got to touch his instrument. Nevertheless, the tool pool there was an enlightened one. Besides the specialized video gear, there was a Buchla box, well-suited for controlling video. "The Bench", constructed by Larry Templeton, produced numerous works mostly by Roarty, Gwin and Hallock. "Painting in time" was how they used to describe the process.

Whatever the original agenda might have been, here was a group of people who defined a highly personalized and unique pictorial style, something quite incompatible with the interests of a broadcast station (KQED).

W.V.

BECK HOLDS A DEGREE in electrical engineering from the University of California, Berkeley, and also studied at the University of Illinois, Urbana in electronics and electronic music. He constructed his first direct video synthesizer in 1969, and another synthesizer while affiliated with the National Center for Experiments in Television, San Francisco. His videographic work includes many compositions realized with the Direct Video Synthesizer on video tape, in live performance, and videofilms. Presently he works from a studio in Berkeley, California, where he founded Beck-Tech Corporation as a microelectronic product research and development company. He was born in 1950 in Chicago, Illinois.

"I WENT TO SCHOOL at the University of Illinois and was very fortunate to find the experimental music studio in Champagne/Urbana. They were looking for somebody to wire things together and I got the job. The University of Illinois was a very happening place in the late sixties because of Lejaren Hiller, Herbert Brim and a technical guy named James Beauchamp who was actually an electrical engineer. That was in 1968. We had one of the first Moog synthesizers and we had built something called the Harmonic Tone Generator. Sal Martirano was one of the most progressive and daring of the music faculty and was very kind to all of the students who showed any interest at all. He'd invite them into his home and we'd sit around and have discussions and play music. I admired him immensely because he took it upon himself in his middle age to learn electronics, circuit theory, and digital logic in order to progress his art.

At the time there was a lot of experimentation with consciousness altering substances such as cannabis, LSD-25, mescaline and shamanic rituals. We'd get together to chant and induce visions and hallucinations. This all fascinated me because for as long as I could remember I'd always seen lots of images when I closed my eyes which I later learned were called phosphenes and hypnogogic, hypnopompic, eidetic imagery.

I started to design conceptual circuits that would go beyond the oscilloscope and vector display. My perception at that time was that here was this incredible technology of color television, which I understood thoroughly at the technical level, which just cried out to be used for some higher purpose. There was also at that time a tremendous amount of resistance against the war in Vietnam. All of us were in danger of being drafted and we were protesting. There was this incredible opposition to what I saw as technological genocide. Here was this technology and people hated it because it was so destructive and at the same time, that technology was being used to go to space. That was the positive manifestation of that technology.

I was studying electrical engineering and I was kind of an apologist or promoter of that positive aspect of technology. I always wanted to make something beautiful out of television as my premise. I was making oscilloscope movies in the electronic music studio and Ron

Namath filmed some of them. Sal Martirano saw what I was doing and he was really enthusiastic and he asked me to start performing with him. I would go to his house with other students and we'd design gates and digital circuits and try to wire them up. It was this huge construction with thousands of patchwires.

I arrived at KQED in August of 1970 and immediately started ordering equipment to build a synthesizer. I met Richard Felciano and we started collaborating on some studies using the Buchla Synthesizer and my machine. I had designed my voltage range inputs to be compatible with the Buchla Synthesizer thinking, I'll go look Buchla up and maybe we can team up and make something. I started to produce imagery and also it was my first opportunity to work with videotape."

S.B.

### **DIRECT VIDEO SYNTHESIZER (ZERO AND ONE)**

The first Beck video synthesizer was later called Direct Video Zero. Direct Video #0 (DV #0) was an expansion of Beck's Illinois experiments, consisting of a modified color television set, with modulation sources driving the color CRT's red, green and blue electron guns. Colors were formed from oscillators and audio signals combined with external analog mixers. The modulation sources were pulled from a Buchla Electronic Music synthesizer to visualize sound. These color images were named "Direct Video" by Brice Howard, director of NCET.

The difficulty of using audio that "sounds good" to form an image that "looks good" was problematic in DV #0. The most interesting images were found from sound sources which were harmonically related to the vertical field rate (60 HZ) and/or the horizontal rate (15,750 KHZ), frequencies not common to audio synthesizers. The search for dedicated sources of video patterns, and a grant from the National Endowment for the Arts in 1971 evolved into the Direct Video Instrument One (DV #1).

The central element of DV #1 to generate the "direct video" image was called by Beck a "voltage to position converter". The converter was loosely based upon a "wipe generator" of a conventional video switcher. The wipe generator consists of a horizontal and vertical locked ramp generator locked to the horizontal and vertical sync. The ramps are compared against "wipe voltages" from knobs to determine the size and position of a switching signal that appears to "wipe" one image over another. The wipe circuitry was modified, replacing the knobs with voltage control of its operation. An input voltage changes the size and/or position of the waveforms triggered by the comparison point along the horizontal or vertical axis. DV #1 modularized this converter, then added an edge extracting "Outliner" that was wired to binary logic gates. The combined signals were patched into multiple color voltages summed together to feed an RGB to NTSC Color Encoder. The use of the NTSC encoder replaced "driving the guns" of the CRT in DV#0, and enabled the results to be recorded on video tape. DV #1 was constructed in a rack mount chassis with two rows of modules and patch cables formed from 1/8" mini-phonograph cables. The modules include:

- 1) Two dual axis joystick controls
- 2) A Horizontal and Vertical Ramp generator
- 3) An H or V phase-locked voltage controlled oscillator generating a triangle and square wave output. Non-linear waveshaping was later added.

4) Eight Voltage to Position Converters — switch selected on H or V, to generate rectangular pulses. These pulses are controlled in position and width under voltage control. Output of these modules are gated together in the binary "geometric region processor".

5) An array of binary functions called an "octal geometric region processor." A collection of eight digital functions of two signals: A and B, A or B, A EXOR B, are used to combine the rectangular pulses formed by the Voltage to Position Converter modules.

6) A Video Outliner called a "geometric unit generator" generates lines and points. The outliner has a horizontal edge extractor formed through delay of the video signal, and "EXOR-ed" with itself.

The extracted left and right edges is selected to pick off the leading or trailing edges of the image. These horizontally derived edges trigger a 1-8 line "monostable" to form a rough approximation of vertical edge.

7) A Dual Video Processor — with gain and a "threshold control", to "core" out, and truncate video signals below a certain level. The processor can alternately be used as a level converter to translate audio signals to DV# 1 levels. This concession allows camera images to enter the direct video data path.

8) One Quad Mixer module — with 11 input patch connectors. Four front panel thumbwheel switches assign the patched signals from the pattern generators to one of the four color channels labeled A,B,C and D. Each of the four channels has a "gate" input to "turn-to-black" or turn off the signal with a video speed control voltage. Switch #0 is connected to a flat color field, switch #9 and # 10 are hard-wired for the two external camera inputs of the Dual Processor. Each of the four channels has a low pass filter to smear the image, called a "texture generator" and can be set to either a horizontal or vertical time constant. Each of the four outputs drive a master level control which wires over to the Color Chord modules.

9) Four Color Chord modules — These modules superimpose the Quad Mixer output into triplets of red, green and blue levels which drive amplifiers with non-inverting and inverting inputs. Each module is controlled by its own set of six knobs, the superposition of the signals appearing as "color chords". Three knobs are assigned to the noninverting Red, Green and Blue amplifiers, and three other knobs to the inverting or "negative" side of these differential output amplifiers. The amplifier outputs are DC restored then passed along for final output to the RGB to NTSC Encoder. A 3M NTSC color encoder and Telemation. NTSC color sync generator develops the timing and final video output for DV # 1. A simultaneous monochrome and color video output are available.

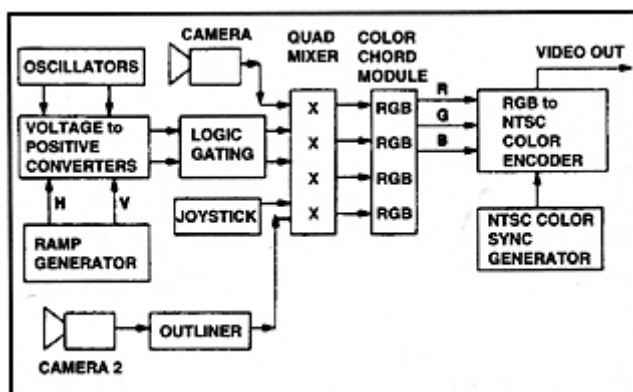

## VIDEO WEAVER

The Video Weaver is a digital pattern generator involving a string of counters and a Random Access Memory (RAM) to hold and later retrieve a stored pattern. It can be viewed as an electronic loom, having a vertical warp and a horizontal weft. The pattern is programmed into the memory then "woven" onto the screen by a set of phase shifting counters that slide and shift their count sequence in time to the video raster. A cursor is available to write in the pattern, while various phasing and counter direction parameters are used to offset the scanning order of the resulting video pattern. It differs from a strict frame buffer design in that the counters that read the memory are not locked into a static scanning order, but drift and wrap-around as the raster progresses.

The 1K by 1 bit static RAM memory stores patterns that are entered in an orderly or randomized sequence, with data locations pointed to by a "write cursor". The cursor is a Point or "cross-hair" that is locked horizontally and vertically, with a pushbutton that enables the entry of data. Timing, sync and the output colorizer were borrowed from the DV# 1. The cursor timing was pulled from the Voltage-to-Position-Converter, and adjusted with a joystick. Later design of a digital cursor allowed for stable, and repeatable positioning.

A set of three "cascaded" 4 bit counters are arranged so that a first counter (C) feeds a second (B), which feeds a third (A). The end counter (A) is clocked at the subcarrier rate and loaded from the second counter (B) at each horizontal sync pulse. The second counter advances at the horizontal rate and is loaded from the first counter (C) every vertical interval. Each of the three counters has its clock input routed through a clock divider. The output of these two end counters (A and B) form an 8 bit address to access the pattern stored in memory. The front counter counts an elapsed frame count and controls the speed of the pattern. Four banks of patterns are stored in the pattern memory. This sequence of wrapping address counters causes a pattern of harmonic rich images. The use of the subcarrier as a horizontal clock generates a staggering line position adding texture to the image.

The pattern memory output, along with selected memory address bits, are combined and converted into a composite color video signal in the DV#1, using the Quad mixer and Color Chord modules. The Weaver was used as an image source for video tapes made by Beck, while his experiments in pattern storage and display formed the basis for his later design work in video games.

J.S.

THE VIDEOWEAVER has been "reincarnated" in 1992 specially for the Ars Electronica "Pioneers of Electronic Art" exhibition. The reincarnation impliments the original 1974 digital design within two ASIC chips that replace the 60 original 7400 series TTL logic chips. The functionality is the same. The new Video Weaver implimentation utilizes PLCA chips, programmable logic cell arrays, to include all counters and logic within a single CMOS gate array of 3000 gates. The user control and interaction is via manual switches and patching. (Engineering of the new LCA is by Stephen Beck, with the assistance of Kevin Fischer and Dave Barr. Additional assembly by Bob Vanegas.)

S.B.

